

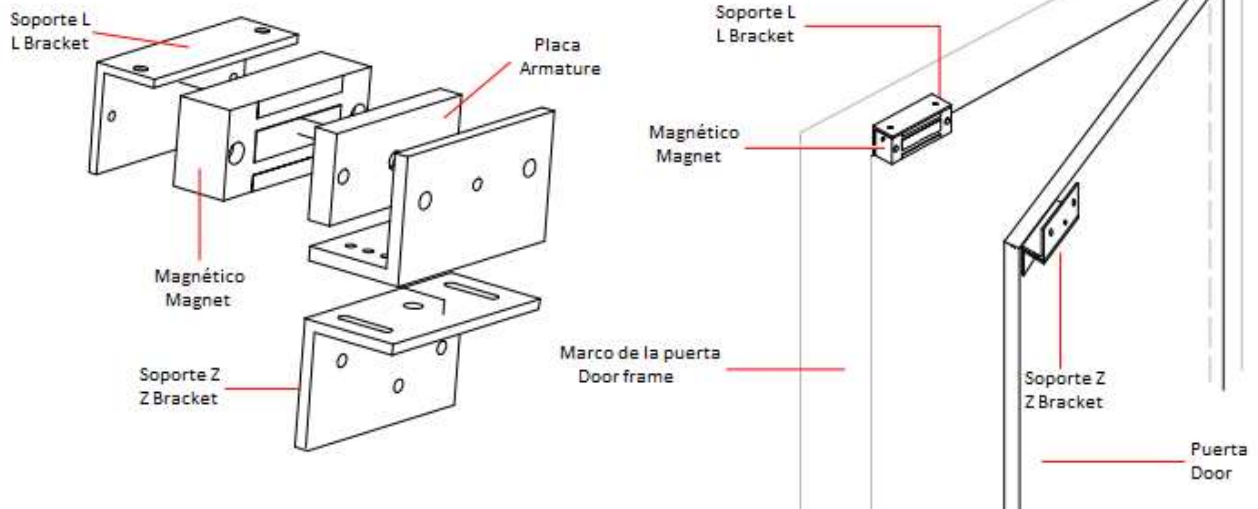

INSTRUCCIONES DE INSTALACIÓN INSTALLATION INSTRUCCIONS

1807



**Debería aplicarse una rosca adecuada a todos los tornillos de fijación
A suitable threadlock should be applied to all fixing screws**

Dibujo Drawing	Cantidad Quantity	Especificación Specification	Cerradura Lock	Soporte Z Z Bracket
	2	Arandela acero Steel washer 12mm* DIA	<input checked="" type="checkbox"/>	<input type="checkbox"/>
	1	Llave Allen Allen key 3mm	<input checked="" type="checkbox"/>	<input type="checkbox"/>
	1	Receptor tornillo placa Armature bolt receiver M5*32mm	<input checked="" type="checkbox"/>	<input type="checkbox"/>
	1	Tornillo placa con goma Armature bolt w/rubber M5*35mm	<input checked="" type="checkbox"/>	<input type="checkbox"/>
	2	Tornillo avellanado Countersunk screw M4*25mm	<input checked="" type="checkbox"/>	<input type="checkbox"/>
	1	Arandela goma Rubber washer 10mm DIA	<input checked="" type="checkbox"/>	<input type="checkbox"/>
	2	Pin guía Guide pin 5*16mm	<input checked="" type="checkbox"/>	<input type="checkbox"/>
	2	Tornillo fijación autoblocante Fixing screw (nylocked) M4*20mm	<input checked="" type="checkbox"/>	<input type="checkbox"/>
	1	Tornillo detención mecanismo Machine stop screw M4*4mm	<input type="checkbox"/>	<input checked="" type="checkbox"/>
	5	Tornillo mecanismo Machine screw M4*7mm	<input type="checkbox"/>	<input checked="" type="checkbox"/>
	1	Llave Allen Allen key 2mm	<input type="checkbox"/>	<input checked="" type="checkbox"/>
	3	Tornillo avellanado Countersunk screw M4*25mm	<input type="checkbox"/>	<input checked="" type="checkbox"/>

Especificaciones eléctricas / Electrical specifications

Voltaje entrada/Input voltage: 12VDC (+/- 15%)
Corriente entrada/ input Current: 140 mA

Voltaje entrada/Input voltage: 24VDC (+/- 15%)
Corriente entrada/ input Current: 70 mA



NADAL BADAL, S.A. – C/Electricitat, 12 – Pol. Ind. Santa Rita – 08755 Castellbisbal (Barcelona)
Telf: + 34 93 772 01 03 – Fax: + 34 93 772 13 63 www.jis.es

(07371)